



Morgana SC6500
Automatic Die-Cutter

Morgana SC6500

The **SC6500** combines **ultra-reliable feeding** with an **instant job retrieval** system and flawless **high-speed cutting** and **creasing**.

The SC6500 is a compact dual tool digital cutter offering a highly advanced and reliable high capacity (900 sheets) auto-sheet feeder to cut and crease light sheet card (up to 350micron), or labels, to any shape without any set up costs. With its unique and reliable vacuum belt feeder, the SC6500 can be left to cut unattended, while the camera registration system automatically retrieves cut files by reading the QR codes on each sheet.

Targeted for busy print departments, seeking an affordable, high-capacity device for complete unattended cutting production, the SC6500 combines ultra-reliable feeding with an instant job retrieval system and flawless high-speed cutting and creasing. This compact free-standing device is conveniently mobile and will be easily accommodated in any print shop.

Market leading features

- Digitally cut-through any shape sheet card item - with SmartTag retention - on up to 350 micron media, or kiss-cut sheet labels - all at up to 960mm/sec
- Digital process means no more costly dies or waiting time
- Auto feeder stacks up to 900 sheets. Up to 340mm x 710mm and custom sizes - with self centring function and air bladelite separation
- Extendable paper tray
- Integral media storage area
- ColorCut Pro - Production Studio software included
- * QR codes and SmartMarks are generated as part of the included ColorCut Pro software plugin which integrates with vector artwork created in Adobe® Illustrator® and CorelDRAW®
- QR* code/Job Library retrieves associated cut files - even for mixed job batch sessions or rotated sheets
- SmartMark registration delivers incredible accuracy - enabled via included ColorCut Pro software



Complete standalone operation - even with a stack of mixed jobs

- 8th generation Vision3 CCD camera reads and instantly retrieves cut files for every sheet on the fly! Accepts a mixed stack of jobs, cutting one after the other in a seamless and uninterrupted flow
- Dual 'Grip and Drive' feed system holds media during cutting on both sides of the cutting head, enabling it to cut closer to media edges
- Revolutionary cutting strip, based on the superior cutting mats used in Intec flatbeds, delivers an optimal surface for both cut-through, creasing and kiss-cut
- SmartTags are left in the cut lines to retain the item in the sheet - leaving a tidy and manageable stack of finished complete sheets in the catch tray
- High-capacity auto feeder works in conjunction with air blade separation and automated jog function, to present every sheet perfectly for the cutter, every time
- New HELD mode allows running 'without wires' or external connections. Using the new HELD mode, jobs can be driven directly on the machine itself, without connection to a computer.

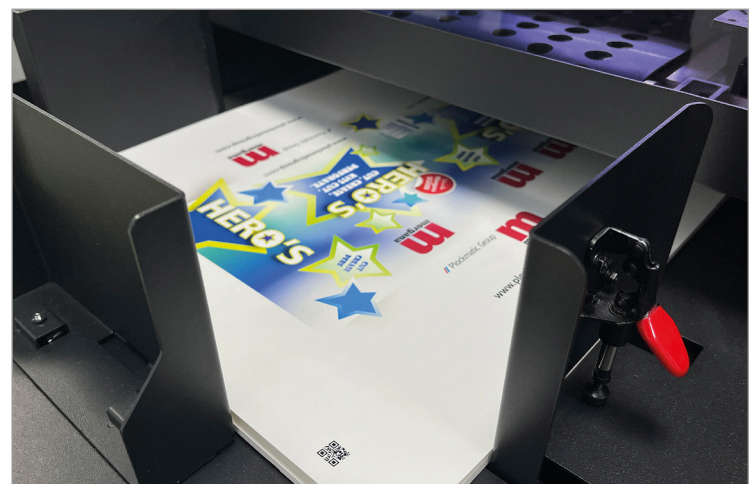

Morgana SC6500

High-capacity and ultra-reliable feeding

The SC6500 has been designed to provide unattended operation with particular attention paid to the feeding system to ensure class-leading performance for card, vinyl labels or even tricky laminated sheets. The SC6500's auto feeder accepts up to 900 sheets, which automatically raises and lowers as required. To prevent sheets curling, as a result of a constant air flow to the sides, the SC6500's uses an automatic air blade that fires a blast of air momentarily into the front of the stack just as the advanced vacuum feed belt lowers to collect the top sheet using pneumatic suction. To further provide a reliable feed, the vacuum feed belt lifts the media carrying any sheets not pre-separated by the air blade past a pair of dexterous separation fingers which dislodges them. Finally before advancing the sheet into the cutting engine, the vacuum feed belt 'jogs' briefly against the rear paper stop, creating a natural curve that helps ensure even difficult media feeds faultlessly.

Dual tool power - digital accuracy

The digital cutting head can apply up to 760gf, individually for both the cutting and creasing tools. Their actions are controlled via the included ColorCut Pro software. In common with the entire ColorCut family, the SC6500 can be set to apply exact amounts of pressure and speed, along with total control over the application of cut, crease and perforation of the vector artwork lines.

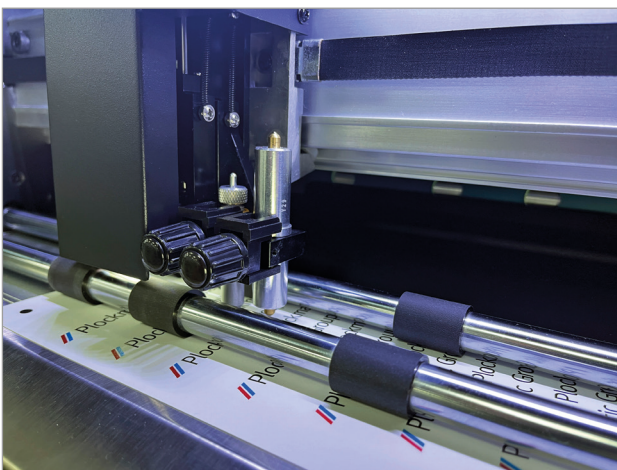

Ergonomic, compact and mobile

The space-saving media catch tray slides away when not in use and the manoeuvrable stand ensures it is easily accommodated into any environment.

The 7 inch immersive touch screen control panel is housed within an articulated module which can pivot to suit the angle desired by the operator.



Easy to use automatic job retrieval

When creating jobs, ColorCut Pro applies an auto-assigned (editable) QR code to each design, whilst auto-saving the cutting file to the ColorCut Pro Job Library.

Jobs with QR codes can be cut at a later date by any operator - no need to search for which file to cut - no specific computer application skills required! The SC6500 checks the QR code on each sheet, retrieves the associated cut file and proceeds to cut and crease as required - even if the sheet is presented at 180°. Choose to cut a single sheet or even thousands on an unattended run.

The Vision3 CCD camera has an 8th generation sensor with enhanced sensitivity to read even white QR codes and SmartMarks, when applied on dark media.

Optional ColorCut Pro Server Station

Seriously enhances productivity. Supplied complete with pre-installed Windows® PC and

ColorCut Pro software suite, with a flat screen monitor, mouse and keyboard.

Also includes software User Licence for 2 additional seats, Template maker with pre-designed jobs.



ColorCut Pro Server Station and Software



The optional ColorCut Pro Server Station streamlines production workflow and automates productivity.

In the design phase, jobs created by graphic designers using ColorCut Pro Client are saved into ColorCut Pro's Job Library. **Production Studio:** The core application for production and operating of the cutter. The easy-to-use interface enables an operator to position sheets for cutting and click START on the software. The QR code printed on the job sheet enables ColorCut Pro Production Studio to automatically and instantly retrieve the correct cutting file, then start cutting your jobs. Job numbers can also be used, enabling an operator to load and send jobs directly to the cutter without need for any additional software.

ColorCut Pro's Job Library Manager: Adds a sophisticated level of control enabling custom job naming and identification, searching, viewing and even assigning unique or custom actions to specific QR codes or job numbers (only available with the ColorCut Pro Server Station).



The **Server Station** is supplied complete with a pre-installed Windows® PC and ColorCut Pro software suite, with a flat screen, monitor, mouse and keyboard.



Production Studio is the core operating software



Template Maker enables designers to create simple cartons and shaped items



Job Library Manager sophisticated job management, with custom action assignment



User Licence allows 2 extra user seats

Template Maker: Create die-cut templates for a range of simple cartons and shaped items, with your own dimensions, in just a few seconds.

The intuitive program allows for a wide range of options to tailor X, Y, Z dimensions, flaps, tucks, creasing and perforations etc. Templates can then be exported to Adobe Illustrator or Corel-DRAW for immediate use.

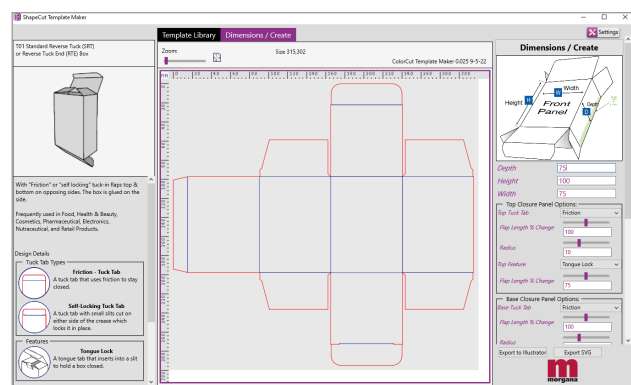
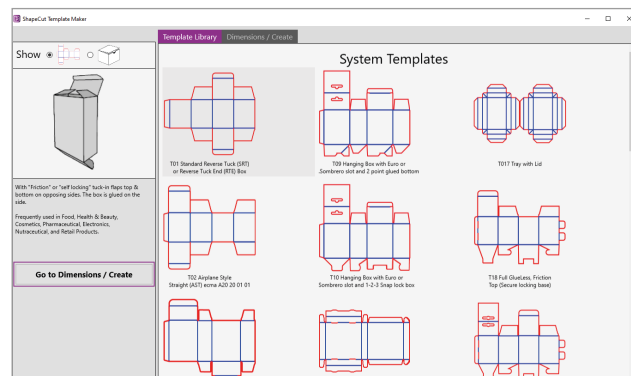

Technical Specifications

Morgana SC6500 Auto Sheet Cutter	
Max media size	340mm x 710mm
Effective contour cutting area	330mm x 700mm
Crease capability	760gf Max 350micron/gsm
Auto-sheet capacity	105mm stacker height or 15kg (Up to 1,000 sheets of 80gsm media for auto-sheet feed)
Custom size label media	Min-Max width 180 x 340mm / length 297 x 210mm
Cutting force	760gf
Type of cut	Die-Cut (with tags), Half Cut (Kiss-cut) & Perf
Max. speed	1060mm per second
Weight (unpacked) inc. stand	136kgs
Power supply	100-240v 50/60Hz, 320W

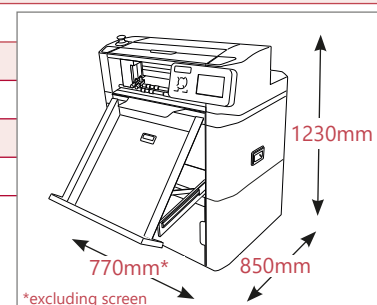

*Disclaimer As part of our continued product improvement plan, specifications and information published here are subject to change without notice. All specifications are dependent on application, type of stock, temperature, RH and print engine used. Specifications quoted were measured on uncoated and unprinted stock. E & OE.